



US9456702 (09-19)

Operator's Manual & Parts List

Compression Sprayers: 454, 456, 458, 454-HD, 456-HD, 458-HD, 454-V, 456-V, 458-V, 458-Rollabout.



If you are missing parts, instructions or have questions, DO NOT take this unit back to the store. Call 1-800-SOLO-INC. Solo will send the missing parts/information to you promptly.

WARRANTY:

Solo Compression sprayers listed above are covered by Solo's 5-YEAR LIMITED WARRANTY. Solo manufactured parts which fail due to defective material or workmanship will be repaired or replaced without charge. See page 6 for full details.

SAFETY PRECAUTIONS:

- Do not exceed 45 psi pressure.
- Do not fill with, use or spray flammable materials.
- Do not use gasoline, acid, acetone, caustic or potentially injurious chemicals.
- At the time of manufacture of this sprayer, we are not aware of any approved plant protection chemicals which would adversely affect this sprayer when applied in their usual concentration.
- Observe the recommendations of the chemical manufacturer.
- Prior to removing any part of the sprayer pull the pressure relief valve to release any pressure in the tank.
- Wear rubber gloves, safety goggles and appropriate protective clothing.
- After pumping be sure handle is in the locked down position.
- Individuals should be trained in the proper use of this sprayer. Where training is not available, individuals should study and follow the procedures detailed in this manual.
- Do not use acetone based chemicals.



WARNING:

Chemicals can be harmful to individuals and the environment if improperly used. In addition, some chemicals are caustic, corrosive, or poisonous and should be avoided. Read warnings and chemical manufacturer's instructions. Solo high density polyethylene sprayers are fitted with Viton® seals which are resistant to a wide variety of agricultural, industrial and household chemicals; however, care should be exercised to ensure that sprayer components are clean, functioning properly, and in a good state of repair before and during use. If in doubt about a particular chemical, check with manufacturer. If you suspect or observe indications that the material may be unsafe in a Solo sprayer... STOP! Do Not Use or Apply Chemical. **ALWAYS WEAR RUBBER GLOVES, SAFETY GOGGLES AND APPROPRIATE PROTECTIVE CLOTHING.**

- Read and follow operating instructions.
- Do not fill sprayer over maximum fill mark. Releasing pressure in an overfill condition can cause harmful venting of sprayer contents.
- Relieve pressure only with sprayer upright and while standing on the side of the sprayer opposite the pressure relief valve. Venting of sprayer contents can occur if liquid is over bottom of relief valve.
- CAUTION: To prevent injury from ejected pump assembly and/or solution, never stand with face or body over the top of the tank when pumping, or loosening pump.
- Do not modify sprayer or pressure relief valve.
- Never spray in the direction of humans, animals or property which might be injured or damaged by spray formula.
- Do not use disinfectants, solvents or impregnating agents unless first tested to ensure they are not harmful to the environment and sprayer.
- Do not use liquids with a temperature above 120°F (45°C).
- Remember that a sprayer with liquid is a significant amount of weight (8 lbs. per gallon). Use caution when bending, leaning or walking. Bend only at the knees and support yourself as required to ensure personal safety.
- Do not inflate sprayer without liquid in the tank.
- Do not climb on ladders, trees or other unsteady or potentially unsafe structures.

ASSEMBLY INSTRUCTIONS FOR WAND

1. Ensure that the O-ring is on the non-threaded end of the wand.
2. Insert the non-threaded end of the wand into the O-ring into the open end of the shut-off valve.
3. Tighten the screw cap.

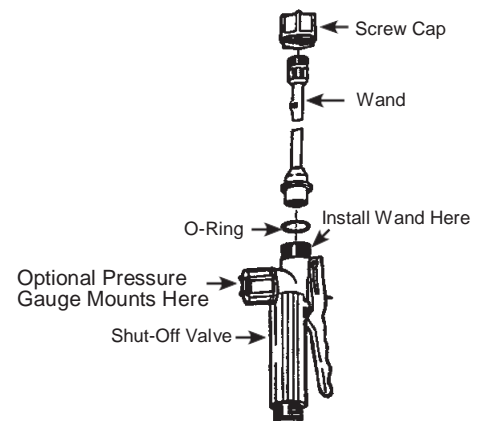

CUSTOMER SERVICE COMMITMENT FROM SOLO'S SERVICE DEPARTMENT

In the event the sprayer you have purchased has missing or damaged parts, please call 1-800-765-6462, 9:00 AM—5:00 PM EST. In order to assist your service representative, please have the following information available: sprayer model number, part description and part number. A parts list is included in your operator's manual.

Solo is committed to your satisfaction and is continuing its efforts to earn your future business.

Visit us on the web at us.solo.global
Troubleshooting and parts ordering available online.

USING THE ADJUSTABLE NOZZLE

To change the spraying pattern, first make sure the retaining nut (2) is screwed tight to the elbow (5). If it is not tight, the nozzle cap (1) and nozzle body (3) will rotate inside the retaining nut and the nozzle will not adjust. For a straight stream pattern, rotate the nozzle cap outward. For a hollow cone pattern, rotate the nozzle cap inward towards the retaining nut. If it becomes difficult to rotate the nozzle cap, remove the nozzle cap from the nozzle body and lubricate the O-ring on the nozzle body with a non-water soluble grease*.

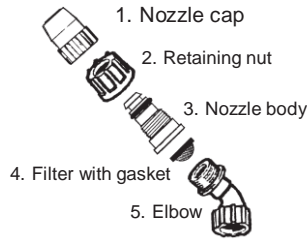

REMOVING ADJUSTABLE NOZZLE

Unscrew the nozzle cap (1) from the nozzle body (3). This is best accomplished while the retaining nut (2) is securely fastened to the elbow (5). Next, unscrew the retaining nut (2). Push the nozzle body (3) out of the retaining nut (2). The filter (4) will come out with the body. To re-install the nozzle, reverse the above instructions.

OPERATION:

- Before using sprayer with chemicals, fill sprayer with fresh water to assure that you have it properly assembled; pressurize and then practice spraying. When thoroughly familiar with sprayer operation, follow normal operating procedures.
- Turn pump handle counter clockwise to remove pump.
- Fill tank with premixed formula up to desired level. (**Do not exceed maximum fill mark.**) Observe recommendations of chemical manufacturer.
- Tighten cap and pump assembly for a good seal.
- Pump to a maximum 45 psi or 3 bar pressure. The valve stem on the pressure relief valve will rise up to vent excess pressure over 45 psi.
- Start or stop spraying by squeezing or releasing the lever on the shut-off valve (3). The spray pressure can be monitored with an optional pressure gauge.
- Prior to every removal of pump (1), release pressure first by pulling up on the pressure relief valve stem (2).



CLEANING:

- Carefully clean sprayer after every use.
- Pour or spray all remaining chemical out of sprayer.
- Pour a small amount of water for water soluble chemicals, or mineral spirits for oil-based chemicals, into the tank.
- Pressurize and spray through system until all liquid is gone.
- Repeat process with warm soapy water.
- Repeat process with warm clear water.
- Use an absorbent cloth to dry all internal surfaces.
- Follow the recommendations of the chemical manufacturer for disposing of waste water and chemicals.
- Do not use aggressive or abrasive cleaning agents.

MAINTENANCE:

- Prior to storage, empty, clean and dry sprayer.
- Always store the sprayer in a dry area, protected from freezing, heat and sunlight.
- Lubricate O-ring in pressure relief valve with non-water soluble grease* on a regular basis.

Disassembly: Unscrew pressure relief valve from tank and pull the valve body out of the screw cap. Clean, lubricate, and replace.

- **Pump Maintenance:** Pump pressure sealing is accomplished with an O-ring (5) on the pump piston (4) which moves within the cylinder (3). Periodically this O-ring should be greased with a non-water soluble grease*. If worn, it should be replaced. A small umbrella valve at the bottom of the cylinder prevents the formula from entering the cylinder. Keep these parts clean and replace if worn.

Disassembly: Unscrew pump assembly from tank. Carefully remove umbrella valve (6) from the bottom of cylinder (3). While holding cylinder firmly with one hand and the handle of the pump piston (4) firmly in the other, with the piston fully inserted in the cylinder, pull back on the piston quickly and forcefully. To re-assemble, place the piston assembly back into cylinder, place heel of hands on opposite sides of the tank cap, while keeping cylinder in place with fingers, tap bottom of cylinder against a flat padded surface. Assembly will lock into place.

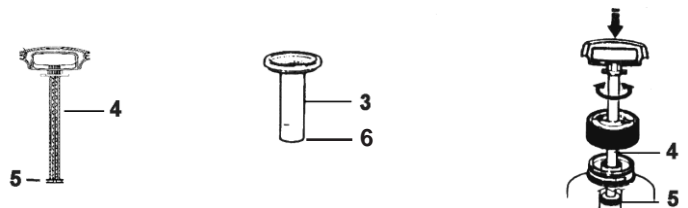

- **Tank Cap:** A small amount of non-water soluble grease* on tank cap threads and both sides of the gasket eases tightening and loosening.
- **Regular Inspection:** Inspect and replace worn or damaged parts promptly. Pay particular attention to tank cap gasket, pressure relief valve and seal, inflation valve (if fitted), umbrella valve O-rings and seals throughout sprayer. Regular lubrication of O-rings and seals is recommended.

* Solo Superior Grease or petroleum jelly work well.

Note: Always wear rubber gloves, safety goggles and appropriate protective clothing when repairing a sprayer. Once a repair is completed, fill the unit with clean water, pressurize, and check for leaks. If the sprayer leaks, **DO NOT USE**. Repair leaks and re-check.

SERVICE AND REPAIR SECTION HANDHELD SPRAYER TROUBLE SHOOTING

PROBLEM	CAUSE	SOLUTION
Difficulty in moving pump handle	<ul style="list-style-type: none"> • dirty cylinder wall • O-ring on piston swollen (not cleaned properly) 	<ul style="list-style-type: none"> • remove piston, clean, grease and replace • replace O-ring, grease
Low pressure & resistance during pumping	<ul style="list-style-type: none"> • No lube on piston/cylinder • Chemical in cylinder • Damaged O-ring in pressure relief valve • worm or damaged O-ring in shut-off valve • tank cap not tight 	<ul style="list-style-type: none"> • lubricate with heavy grease • Replace umbrella valve • replace O-ring • replace O-ring • tighten cap
Leaks from end of spray wand	<ul style="list-style-type: none"> • worn or damaged O-ring in shut-off valve 	<ul style="list-style-type: none"> • rebuild shut-off valve
Leaks from inside cylinder	<ul style="list-style-type: none"> • no lube on piston cylinder 	<ul style="list-style-type: none"> • lubricate piston, O-ring and cylinder
Leaks under cap	<ul style="list-style-type: none"> • worn or damaged umbrella valve 	<ul style="list-style-type: none"> • replace umbrella valve at bottom of cylinder
Leaks from shut-off valve	<ul style="list-style-type: none"> • damaged or missing gasket 	<ul style="list-style-type: none"> • replace gasket
Leaks from hose	<ul style="list-style-type: none"> • screw cap not tight 	<ul style="list-style-type: none"> • tighten tank cap
Pressure relief valve sticks	<ul style="list-style-type: none"> • worn, damaged or loose fittings, lack of lubrication 	<ul style="list-style-type: none"> • tighten fittings and replace worn parts, disassemble and lubricate O-rings
Air leak - air coming out between halves of the pump support	<ul style="list-style-type: none"> • worn, damaged or loose fittings • lack of lubrication or contaminated relief valve relief valve assembly • tank cap not tight • gasket twisted or lacking lubrication • tank lip damaged 	<ul style="list-style-type: none"> • tighten fittings and replace worn parts • clean and lubricate pressure • tighten tank cap • straighten gasket and lubricate with grease • repair or replace tank

SOLO LIMITED WARRANTY

Solo Incorporated guarantees the original purchaser of Solo equipment, that any failure of Solo manufactured parts due to defects in material and workmanship occurring during the applicable warranty period will be repaired or replaced without charge for parts or labor, except for those items not covered by warranty.

CONSUMER LIMITED WARRANTY: Solo equipment purchased for consumer use is covered by this Limited Warranty for a period of FIVE (5) YEARS.

COMMERCIAL LIMITED WARRANTY: Solo equipment purchased for commercial use is covered by this Limited Warranty for a period of ONE (1) YEAR.

OPERATOR'S OBLIGATION AND RESPONSIBILITY: proof of purchase must be provided by the owner in order to obtain warranty service. Should any failure covered by this Limited Warranty occur, deliver or ship the Solo products or parts to an authorized Solo service center. Freight, packing and insurance costs, if any, will be borne by the owner. Follow normal maintenance service to include applicable lubrication, operation and storage of the product as explained in the owner's manual.

ITEMS NOT COVERED BY WARRANTY: provisions of the Limited Warranty will not apply to the following: Any indirect or consequential damages that may result from the failure or malfunction of the Solo product. Normal service requirements arising during the warranty period, such as cleaning, normal wear, lubrication, filter, spray tips, etc. Normal service work over and above the repair or replacement of defective parts. Any failure that results from an accident, customer abuse, normal wear, neglect or failure to operate the product in accordance with the instructions provided in the operator's manual or provided with the product. When an alteration or modification has been performed on a Solo product, Solo is responsible only for products as originally furnished by Solo, provided the alterations or modifications do not adversely affect the product's operation, performance or durability. Parts or accessories that are incomplete with the product are not approved by Solo. Full disclosure of Solo's Limited Warranty is available from your local Solo dealer or Solo Incorporated, 5100 Chestnut Avenue, Newport News, Virginia 23605. This Limited Warranty gives you specific legal rights and you may also have other rights which vary from state to state.

PARTS BREAKDOWN

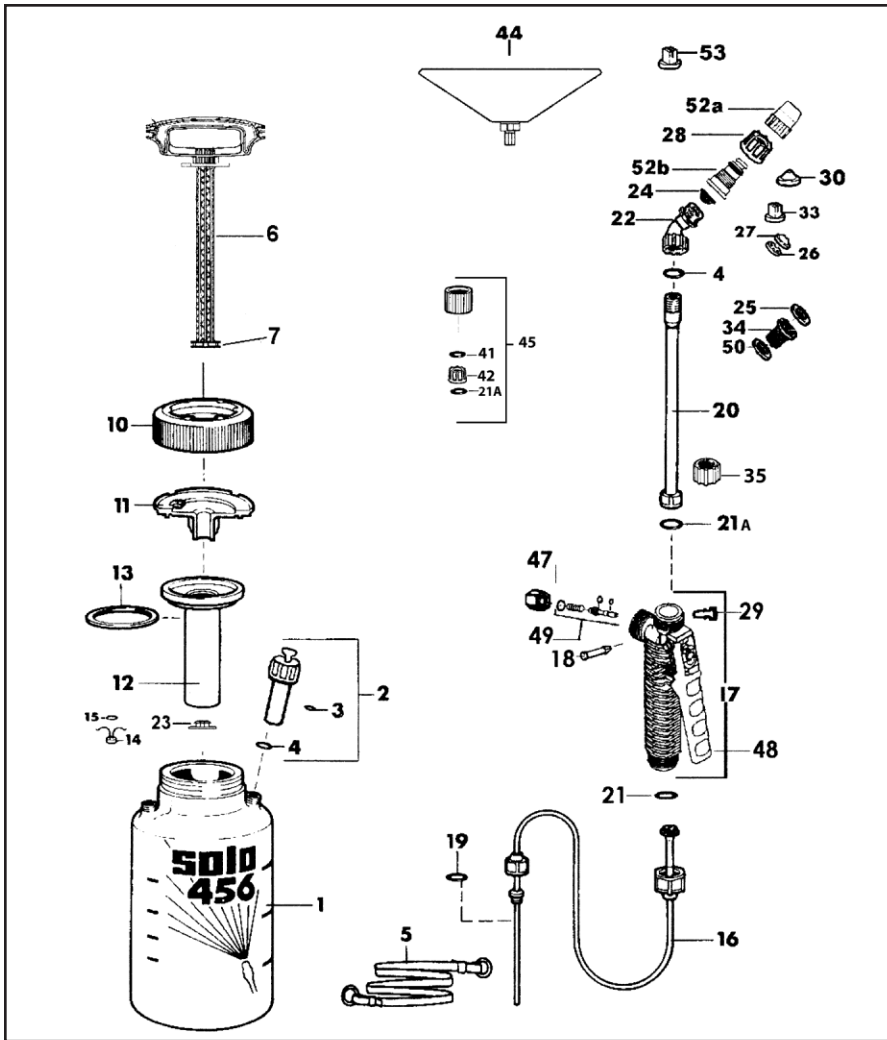

Pos. No.	Order No.	For Model	Description
1	4071262	456	Tank, 2 gallon
-	4071267	454	Tank, 1 gallon
-	4071263	457	Tank, 3 gallon
2	4800185	*	Pressure relief valve assy.
3	0062166	*	O-ring
4	0062115	*	O-ring
5	4300245	*	Carrying strap
6	4073835	*	Pump piston, solid
7	0062264	*	O-ring
10	4073528	HD	Tank cap, red
-	4073111	HD	Tank cap, black
11	4074387	HD	Cylinder support (need 2)
12	4073834	HD	Cylinder
-	4073834	*	Cylinder (use with 0094308)
13	4061345	*	Gasket
14	4074656	*	Valve cone
15	0062165	*	O-ring
16	4900515	***	Pressure hose, assy.
17	4800170	***	Shut-off valve, assy.
18	4074295	*	Pin retaining
19	0062144	*	O-ring
20	4900230	456SW	Wand, assy. (inc. 35 & 21A)
21	4900645	456SW	Stainless Wand
21A	0062271	456SW	O-ring
21A	0062258	456SW	O-ring
22	4074527	*	Elbow
23	0094308	*	Umbrella valve
24	4074283	*	Filter
25	0062106	*	O-ring
26	4074756	*	Swirl plate
27	4074755	*	Jet cap tip
28	4074148	*	Retaining nut
29	4074329	*	Lock clip
33	4074263	*	Flat spray nozzle
47	4074336	*	Retaining nut
48	4074335	*	Lever
49	0610402-K	*	Shut-off valve repair kit
52	4900527	456SW	Plastic adj. nozzle (incl. a & b)
52	4900207	456SW	Brass adj. nozzle

Accessories

Pos. No.	Order No.	For Model	Description
-	4900405-K		Pump repair kit
-	4900407-K	HD	Pump repair kit
25	0062106	HD	O-ring
30	4074726	**	Hollow cone nozzle
34	2700316	HD	No drip check valve
35	4074337	HD	Retaining nut
41	0062249	HD	O-ring
42	4074338	HD	Retaining nut
44	4900430	HD	Drift guard
45	4900622	HD	Pressure gauge assy.
50	0062115	HD	O-ring
53	0065210	HD	Brass flat spray nozzle

* Pump repair kit

***Cut pick-up tube to fit for models 454 and 456

Prices and technical specifications are subject to change without notice.