

Instruction manual
Original instructions

Leaf blower

de

en

fr

es

it

Important!

Read this instruction manual carefully before first operation and strictly observe the safety regulations!



Instruction manual

Original instructions

 **Caution!** Prior to operating the unit, please read the owner's manual carefully, and most importantly, observe all safety rules.

Observe the maintenance guidelines closely to ensure the long service life of your equipment.

Your dealer will be glad to assist you with any questions.

EC declaration of conformity → The EC declaration of conformity **on a separate piece of paper** forms part of these operating instructions.

Packaging and disposal

Please keep the original packaging in order to protect the equipment against transport damage in case you ever need to ship it or transport it. If the packaging materials are no longer required then they must be disposed of properly in accordance with applicable local regulations. Cardboard packaging materials are raw materials which can be recycled or reused.

At the end of the equipment's service life, please make sure that you dispose of it properly, in accordance with the official directives and regulations that apply in your area

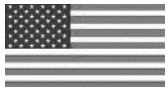

For **USA** only:

Emissions Control Warranty Statement

The Environmental Protection Agency and Solo are pleased to explain the emission control system on your small non-road power equipment engine. In the US new small non-road engines must be designed, built, and equipped to meet the Environmental Protection Agency's standards. Solo must warrant the emission control system on your small non-road engine for the period of time listed below provided there has been no abuse, neglect, or improper maintenance of your small non-road engine.

Your emission control system includes parts such as the carburetor, the ignition system, and the exhaust system.

Where a warrantable condition exists, Solo will repair your small non-road power equipment engine at no cost to you including diagnosis, parts, and labor.

Manufacturer's Warranty Coverage

Solo's small non-road power equipment engines are warranted for a period of two years. If any emission control related part on your engine is defective, the part will be repaired or replaced by Solo.

Contact Information for Authorized Service Center Locations, Replacement Parts, Warranty and Technical Information

Warranty repairs **must** be completed by a SOLO Authorized Service Center.

SOLO USA, Inc. 1-800-765-6462
5100 Chestnut Avenue techserv@solousa.com
Newport News, VA 23605

Symbols

The following symbols are used in this manual and on the product:



Thoroughly read these operating instructions before undertaking any maintenance, installation and cleaning steps



Always handle this power tool with particular care



Prohibited



Wear eye and ear protection



Do not smoke



No open flame



Starting of engine



Switch off engine



Wear protective gloves



fuel mixture



choke open



choke closed



Hint: Medical implant

Type plate



a: Type designation

b: Serial number

c: Build year

Index

	Page
1. Important Components	4
2. Safety regulations.....	5
2.1 <i>Correct use / General safety instructions</i>	5
2.2 <i>Personal protective equipment for your safety</i>	5
2.3 <i>Protection of Environment</i>	5
2.4 <i>Operating Hints</i>	5
3. Assembly.....	6
3.1 <i>Installation of pleated elbow tube</i>	6
3.2 <i>Install multi-function handle and blower tube</i>	6
4. Accessories.....	6
5. Fuelling.....	7
5.1 <i>Safety instructions fuelling</i>	7
5.2 <i>Fuel information</i>	7
5.3 <i>Fuelling</i>	7
6. Starting / Stopping the engine.....	8
7. Operating Hints.....	9
7.1 <i>Adjustment of shoulder straps</i>	9
7.2 <i>Active components of the operating handle</i>	9
8. Maintenance and care	10
<i>General Maintenance Hints</i>	10
8.1 <i>Carburettor adjustment</i>	10
8.2 <i>Air Filter Maintenance</i>	11
8.3 <i>Spark Plug</i>	11
8.4 <i>Shutdown and storage</i>	11
8.5 <i>Scheduled maintenance</i>	12
8.6 <i>Replacement parts</i>	12
9. Technical Specifications.....	13
10. Parts subject to tear and wear.....	14
11. Guarantee	14

In the best interest of continued technological progress we reserve the right to change the design and configuration of any product without prior notice.

For that reason, no claims can be accepted with reference to text and illustrations in this manual

1. Important Components

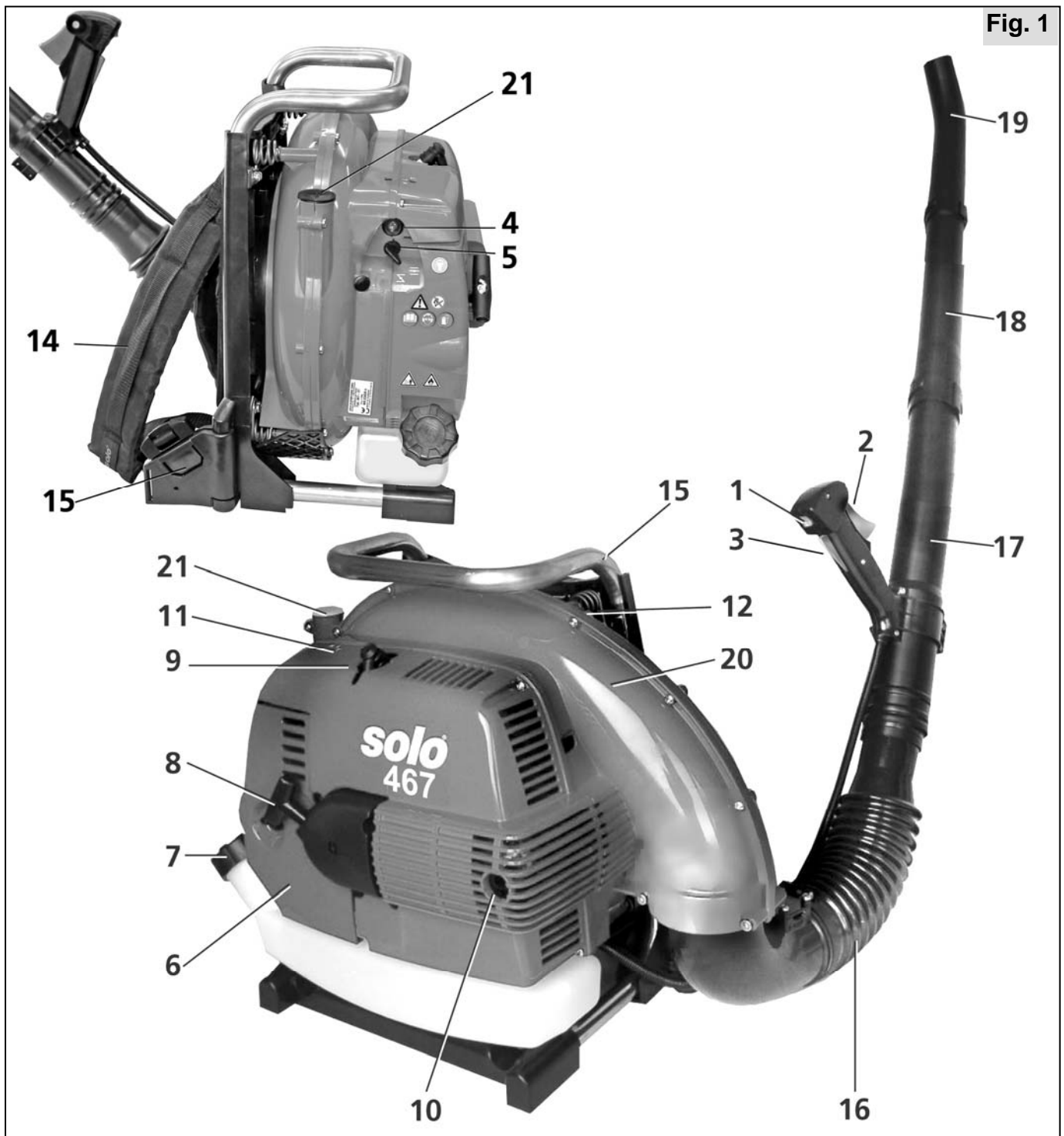

Fig. 1

1. On/Off Switch	11. Carburetor Adjustment Screws
2. Throttle Lever	12. Vibration Absorbing Springs
3. Throttle control lock	13. Quick-Release Carrying Strap
4. Primer	14. Carrying Strap
5. Choke Lever	15. Carrying Frame
6. Air Filter Cover	16. Pleated Elbow Tube
7. Fuel Tank Lid	17. Blower Tube I
8. Starter Handle	18. Extension Tube II
9. Spark Plug	19. Curved Nozzle Tube
10. Muffler	20. Blower Housing
21. Plug (Note: This is where, when converting the equipment into a sprayer, the liquid container is connected)	





2. Safety regulations

2.1 Correct use / General safety instructions





Always observe all safety hints while using the machine.

The blower unit is suitable for the removal of leaves, grass, paper, dust or snow in areas such as gardens or parks, sports facilities, parking areas or drives. The blower can also be used for the removal of leaves and small branches while harvesting stone fruit.

The blower unit may only be used for the purpose it has been designed for– and no other!

-  For despatch purposes, the blower is supplied partially disassembled and has to be fully assembled prior to use. (chapter 3 “Assembly”) The blower may only be operated when fully assembled.
-  Read the operating instructions carefully before placing in service and keep them in a safe place. First time users should be instructed by the seller or an expert.
-  Within the scope of the units operating area, the operator is responsible for injuries to other persons. Operate the blower only when in good physical condition. Fatigue or ill health may lead to lack of attention and care. The machine should be operated in a calm and alert manner.
-  Never operate the blower when under the the influence of alcohol or drugs.
The air exit speed from the nozzle is very high. Never point the nozzle towards persons or animals.

2.2 Personal protective equipment for your safety

-  To prevent injuries to head, eyes, hand, feet or damage to hearing, the following protective equipment should be worn:
-   Clothing should be appropriate for the job, i.e. not too loose and not too tight to be hindering. Do not wear work coat, shorts or sandals. The operator should not wear a scarf, a necktie or jewelry which may get caught by branches.
-  Protect your face and eyes with a face guard or safety glasses.
To avoid damage to hearing, the operator should wear suitable personal noise protection such as ear muffs, ear plugs or similar.

Wear firm work shoes with non-slip soles.

Always observe accident prevention regulations issued by local trade organizations or workers compensation boards.

2.3 Protection of Environment

Be aware of your surroundings

- Watch out for animals which may be within your work area
- Be aware that noise is harmful to the environment. Inquire about and respect possible local rest periods.

2.4 Operating Hints

- Approach blowing task with engine at idling speed, then accelerate to full throttle.
- No other persons should be present within a circle of 15 meters from the operator. Watch out for children and animals. Objects carried by the air stream can deflect and injure nearby persons.
- Never operate on unstable ground watch out for any obstacles such as tree stumps, tree roots, ditches etc..
- Take special care while working along slopes.
- Never touch a hot exhaust.

 This machine produces an electromagnetic field during operation. This field may under some circumstances interfere with active or passive medical implants. Persons with medical implants have to consult their physician and the medical implant manufacturer before operating this machine. You should request and receive instructions from the vendor on the safe operation if you are using this type of product for the first time.

3. Assembly

Completely assembly the leaf blower before its first use:

3.1 Installation of pleated elbow tube

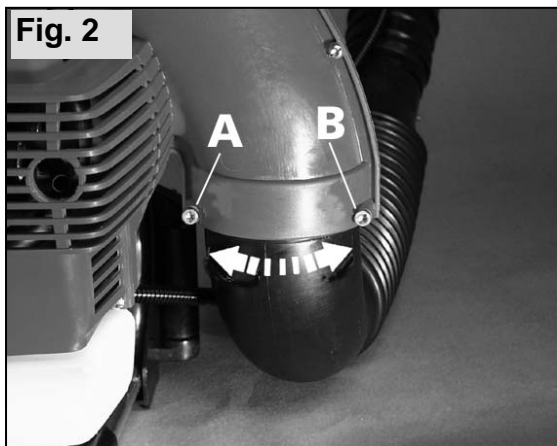

Remove screws A and B.

Push pleated elbow tube (16) into the opening of the blower housing (20) until resistance is felt and re-tighten screws A and B to hold tube in place.

Note: Ensure the pleated elbow tube can be easily swiveled after fitting it to the blower housing.

3.2 Install multi-function handle and blower tube

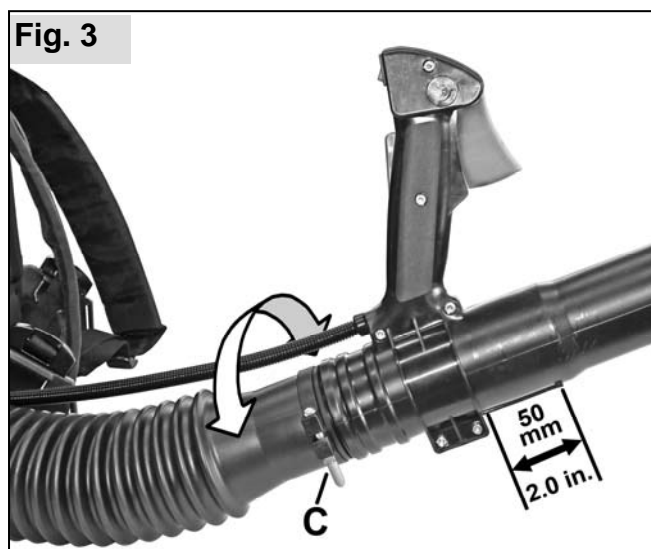

Push multi-function handle onto blower tube and fix with 2 screws in the required, comfortable position. The adjustment scope is approx. 50mm depending on the arm length of the operator.

Push blower tube into pleated elbow tube (16) and secure with plastic clamp (C).

Note: With the multi-function handle the blower tube can now be twisted and swiveled in the pleated blower elbow. Ensure that no cables are disconnected when testing this feature.

- Insert extension tube 2 in blower tube 1 and secure with twist lock
- Push curved nozzle tube on extension tube and also secure with twist lock

4. Accessories

5. Fuelling



5.1 Safety instructions fuelling

- The handling of fuel requires caution and consideration. It is imperative that all safety instructions are observed!
- Smoking or open flame is prohibited.
- Allow engine to cool before re-fuelling.
- Fuel may contain solvent-like substances. Avoid skin and eye contact with mineral products. Wear gloves while refueling. Frequently change and clean protective clothing. Do not inhale fuel vapors.
- Do not spill fuel or oil. In case of spillage, immediately wipe off the power tool. Do not allow fuel mix to contact clothing. If fuel mix is spilled on clothing, change clothing immediately
- Ensure fuel or oil do not contaminate soil (environmental protection). Always use a suitable protective soil cover.
- Do not re-fuel in unventilated rooms. Fuel vapors collect at ground level (danger of explosion).
- Transport and store fuel and oil only in approved and clearly marked containers. Children should have no access to fuel or oil.

5.2 Fuel information



A high performance two-stroke engine operated with a petrol:oil mixture (petrol + oil = fuel mixture) or with a special fuel mixture for two-stroke engines available from specialists powers this machine.

We recommend the proprietary “**Aspen 2-takt**” special fuel mixture. Please observe the special fuel manufacturer’s instructions.

Information on individual mixing of the fuel mixture

Normal or super unleaded petrol can be used for individual mixing purposes (**minimum octane number 92 RON**).

When using a particularly high quality proprietary 2-stroke engine oil such as the “**SOLO Profi 2T-Motoröl**” which we supply, we recommend an oil:petrol mixing ratio of **1:50 (2%)**.

When using **other brands of 2-stroke oil** we recommend a mixing ratio of 1:25 (4%).

Only use **proprietary 2-stroke engine oil!**

Never store fuel mixture longer than 3 - 4 weeks.

Fuel mixture table

Petrol in litres	Oil in litres	
	SOLO 2T engine oil 2% (50 : 1)	Other two-stroke oils 4% (25 : 1)
1	0.020	0.040
5	0.100	0.200
10	0.200	0.400

Unsuitable petrol or deviations in the mixing ratio may lead to serious engine damage!

Avoid direct skin contact with petrol and avoid inhaling petrol fumes - health hazard!

5.3 Fuelling

While fuelling always follow all safety instructions and take all safety precautions.



Handle fuel only with the engine turned off. Carefully clean the area around the filler inlet. Place the machine with the fuel inlet pointing upwards. Unscrew the tank lid and fill the fuel mixture up to the lower edge of the filler neck. Use a funnel with filter to prevent tank contamination. After filling the tank replace the tank lid and tighten firmly.

6. Starting / Stopping the engine



Starting with cold engine

Fig. 4



- Switch On/Off Switch (1) to "I" position.

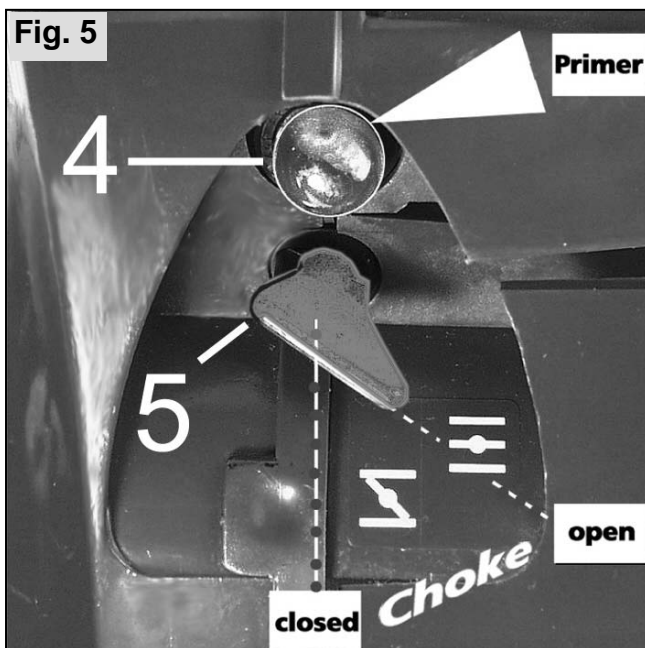

- Close choke with choke lever (5).
- Press primer (4) several times until fuel is visible in the primer.
- Hold the machine with your left hand on the carrying handle (15). With the right hand, slowly pull out the starter handle (8) until resistance is felt. Then pull quickly and forcibly until the engine attempts to start (engine fires).
- Once the engine tries to start, immediately open the choke and continue to start.

- When the engine runs, use the throttle lever (2) to accelerate to the required engine speed.
- To return to idling speed, release the throttle lever.

Starting with warm engine after short stop

- Leave choke in "open" position and start engine.

Should the engine refuse to start despite several starting attempts, the combustion chamber is most likely flooded.

In this case we recommend you remove and dry the spark plug (9). Set the ignition switch to "0". Pull over engine several times, still with spark plug removed. This will ventilate the combustion chamber

Replace spark plug and repeat starting procedure.



Shutting off engine

- Release throttle lever and move throttle lock lever to "min" position.
- Move ignition switch to "0" position until engine stops.

7. Operating Hints



Prior to operating and prior to each start, check the blower unit's condition with regard to throttle activation, on/off switch, protective covers, carrying straps and also for any fuel leaks.

Take care not to inhale exhaust fumes. Do not operate the blower in closed areas.

- Prior to starting the engine and during all jobs, the operator needs to be securely and safely positioned.
- The engine starting site should be at least 3 meters away from the refueling site.

7.1 Adjustment of shoulder straps

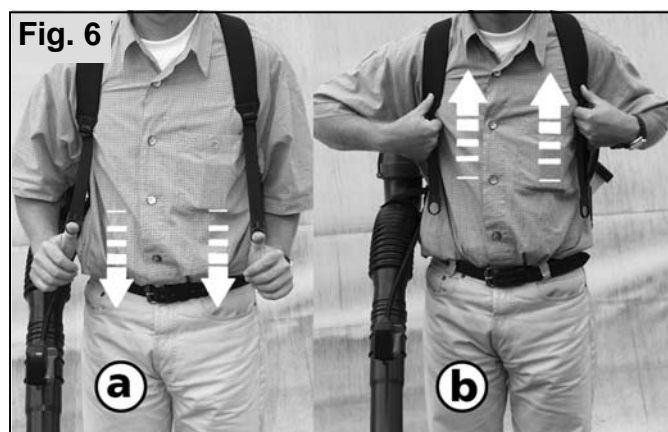

Put blower on back and secure carrying straps with quick-coupling locks (13).

The straps can be adjusted to the required length with friction slides. Simply pull down both strap ends to tighten straps (a).

Strap tension can be released by lifting both friction slides (b).

Note:

The shoulder straps are correctly adjusted when the back plate rests firmly against the back of the operator.

7.2 Active components of the operating handle

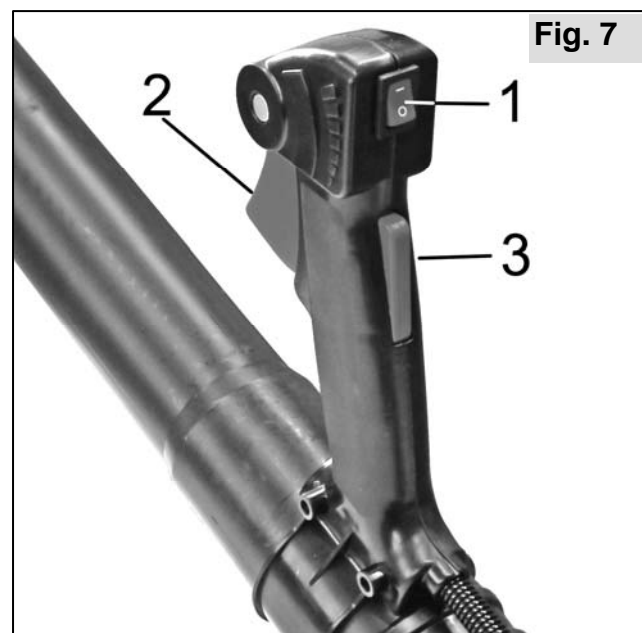

To release the throttle control (2):
 Hold the handle with your right hand,
 → the throttle control lock (3) is activated by the flat of your hand,
 → the throttle control is released.

On/Off Switch (1) "I" → operating position

On/Off Switch (1) "0" → engine off

8. Maintenance and care

Maintenance and repair of modern motorized devices, as well as their safety-relevant assemblies, require qualified, specialized training and a workshop equipped with special tools and test devices. Thus SOLO recommends that you have a specialized SOLO workshop carry out all work that is not described in these operating instructions. Your SOLO specialist has the required training, experience, and equipment at his disposal to provide you with the most cost-effective solution and can help you in many ways with advice and service.

General Maintenance Hints



After a running in period of approx. 5 hours, all accessible screws and nuts (except for carburetor mixture adjustment needles) have to be checked and re-tightened if required. Any service jobs, other than those described in this manual, should only be carried out by an authorized service center.

- Any cleaning, maintenance or repair jobs should only be performed when the engine is stopped and with removed spark plug cap. The exception, of course, is carburetor tuning

Maintenance Guide Lines

- Any service jobs, other than those described in this manual, should only be carried out by an authorized service center. Only original parts may be used for any maintenance and service work.
- Never modify your leaf blower – your personal safety is at risk.
- Never service or store the machine near an open flame.
- Regularly check the fuel tank lid for sealing and tank ventilation. Only use recommended spark plugs. Check ignition cable for any damage.
- Do not operate the blower with a broken or removed muffler. This can lead to fires and cause hearing damage. Do not touch hot muffler.



For transport in a vehicle, ensure the power tool is well secured to avoid fuel spillage.

- Completely empty the fuel tank before extended storage or shipment.

8.1 Carburettor adjustment



The carburettor is adjusted at the factory for optimum performance. Subject to the place of use (mountains, low-lying areas), the average idling speed given in the specification can be adjusted as follows, via the idling end-stop screw "T" (the use of a rev counter is recommended):

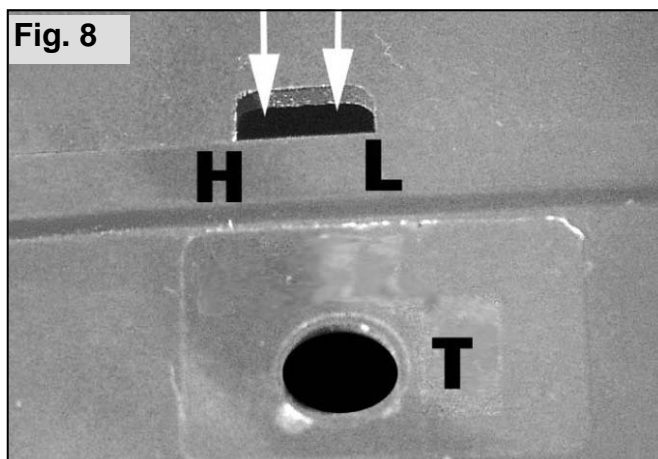

- If the idling speed is too high, turn the idling end-stop screw "T" anti-clockwise.
- If the idling speed is too low (engine stops) turn the idling end-stop screw "T" clockwise until the engine runs smoothly.

If the idling speed cannot be set correctly with the idling end-stop screw "T", request an authorised service centre to tune the carburettor.

The adjusting screws for the idling mixture "L" and the full-load mixture "H" (25) must only be adjusted by an authorised workshop.

The following instructions are for authorised service shops

Use the D-CUT carburettor key to adjust the idle mixture screw "L" and the full load mixture screw "H".

Ask the specialist workshop that is part of our customer service about standard settings, or visit our internet portal for dealers at www.part-and-more.org.

Clean the air filter before adjusting the low speed screw!

Let the engine run warm before adjusting the engine speed.

The carburettor is tuned for optimum engine performance. Use a rev counter to tune the carburettor correctly!

Do not adjust the engine to a higher speed. Excessive engine speed can lead to major engine damage!

8.2 Air Filter Maintenance



The air filter separates and retains dirt before the air reaches the combustion chamber. This reduces engine wear.

Regular maintenance increases engine life.

Clogged air filters cause performance loss and increased fuel consumption. This leads to a higher toxin level in the exhaust gas and also makes starting more difficult.

When the machine is used all day, the air filter should be cleaned daily. In severe dust conditions clean more often in between.

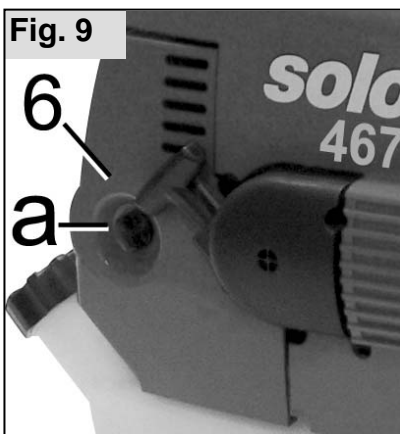

Undo the screw (a) completely (screw is retained inside the filter cover) and remove the filter cover (6).



The best way to clean the filter is to simply tap out any dirt or blow it carefully out with a low blast of air.

Never wash or clean the air filter with high compressed air or by wetting it; never place in an oil bath or into cleaning solution.

If engine rpm's tend to drop although the carburettor adjustments are perfectly set, the air filter cartridge is clogged and must be replaced by a new one (Order-Nr. 20 48 280).

Never do realignments on the factory carburettor settings in order to balance a clogged air filter

system. This procedure would cause engine damages due overload of the engine.

Warranty claims cannot be accepted for damaged engine parts caused by improper care and maintenance.

Insert the new or cleaned fabric air filter into the casing.

Secure the filter cover by turning the screw (a) clockwise.

8.3 Spark Plug



The correct spark plug with thermal range 200 is available under the following brands:

BOSCH WSR6F

CHAMPION RCJ-6Y or similar

The correct electrode gap is 0.5 mm.



Check the plug after every 50 operating hours and replace if electrodes are worn.

8.4 Shutdown and storage



Clean the power tool after use.

- Never use aggressive cleaning solutions or those containing solvents to clean any part of the engine. Never hose down the engine. For best results, simply wipe down the entire engine with a dry or slightly damp cloth.

Store the device in a dry, safe location inside a building (garage, basement, ...). There must not be any open fires or similar nearby. Ensure that the device cannot be used by unauthorised persons, especially children.

If not in use for more than four weeks, drain the fuel tank in a well ventilated location before storing. Start the engine with an empty fuel tank and drain the carburettor until the engine stops. Oil residues from the fuel mixture could otherwise clog the carburettor jets and make it difficult to start the device later.







8.5 Scheduled maintenance



The following information is based on standard operating conditions. For special conditions, such as prolonged daily use, the recommended maintenance intervals should be reduced accordingly.

Implement all maintenance jobs regularly. If required, authorise a specialist service centre to maintain the machine for you. The owner of the machine is responsible for:

- Any damage caused by a lack of maintenance, incorrect or late maintenance and repairs
- Consequential losses - including corrosion - from incorrect storage

		after the first 5 hours	before starting work	after every 50 hours	after every 100 hours	as required	once per year
Carburettor	Check idling speed		X				
	Adjust idling speed					X	
 Air filter	Clean		X				
	Replace					X	
 Spark plug	Check electrode gap and replace spark plug if required			X			X
	Replace				X	X	
 All accessible screws (except for adjusting screws)	Retighten	X				X	X
Controls (stop switch, throttle lever, starter)	Check function		X				
 Silencer	Visual inspection		X				
 Air inlet (Protection screen)	Clean			X		X	X
 Complete machine	Visual inspection		X				
	Clean			X		X	X

Furthermore, as part of the annual service at an authorised dealer, request the following services:

- Complete check of the entire machine
- Professional cleaning of the engine (fuel tank, cylinder head fins, ...)
- Check and, if necessary, replace wearing parts, particularly the annual fuel filter change
- Optimum setting of the carburettor

8.6 Replacement parts

Dependable operation and the safety of your device also depend on the quality of the replacement parts that you use. Use only original SOLO replacement parts. Only original parts come from the production of the device and thus guarantee the highest possible material quality, dimensional accuracy, function, and safety. Original replacement parts and accessory parts are available from your dealer. He also maintains the requisite replacement part lists to determine the required replacement part numbers, and he is constantly provided with information concerning detail improvements and innovations in the replacement part offering. Please note as well that guarantee performances from SOLO are not possible if parts other than SOLO original parts are used.

9. Technical Specifications

Leaf blower	467	
Engine type	SOLO single cylinder two-stroke engine	
Engine capacity	cm ³	66,5
Bore / stroke	mm	46 / 40
Max Engine power (ISO 8893)	kW at rpm	2.1 / 5750
Fuel tank capacity	l	1,9
Fuel mix ratio	with SOLO 2T engine oil with other two-stroke oils	1:50 (2%) 1:25 (4%)
Carburettor	All-position diaphragm carburettor with primer and integrated fuel pump	
Air filter cartridge	Paperstyle	
Ignition	Electronically controlled magneto ignition, maintenance free	
Max. Blower Air Volume *	m ³ /h	1400
Max. Air Speed	m/s	92
Medium idling speed	rpm	2200 ± 200
Permissible speed	rpm	5150 ± 200
Maximum speed of the fan *	rpm	4300
Work Site related noise emission L _{Peq} to EN ISO 22868;	dB(A)	94 ± 2,5 dB(A)
Sound power level L _{Weq} to EN ISO 22868	dB(A)	103 ± 2,5 dB(A)
Weighted effective acceleration (ISO 7916) ISO 7916 on handle	m/s ²	< 2 ± 1m/s ²
Weight	kg	10,0
Dimensions without Tube	mm	hight: 690 / width: 550 / depth: 280

* without Tube

10. Parts subject to tear and wear

Various parts are subject to application- specific or normal wear and must be replaced in good time, when required. The following parts are subject to normal wear and are not covered by the manufacturer's guarantee:

- Air filter
- Fuel filter
- All rubber parts which come into contact with fuel
- Spark plug
- Starter

11. Guarantee

SOLO guarantees problem-free quality and will assume the costs for defect remediation by replacing the defective parts in the case of material or manufacturing defects that occur within the guarantee period after the date of purchase. Please note that specific guarantee conditions apply in some countries. Ask your sales person if you have any questions. As vendor of the products he is responsible for the guarantee. We request your understanding that no guarantee can be assumed for damages due to the following:

- Non-compliance with the operating instructions.
- Neglecting required maintenance and repair work.
- Damages due to improper carburetor adjustment.
- Normal wear and tear.
- Obvious overload through persistently exceeding the upper performance limits.
- Using non-approved tools and cutting fixtures, Using non-approved cutting bar and chain lengths in the case of chain saws.
- The use of force, improper handling, misuse, or accident.
- Damages caused by overheating due to dirt build up on the ventilator casing.
- Intervention by non-specialized persons, or improper repair attempts.
- The use of unsuitable replacement parts or parts other than SOLO original parts to the extent that they cause damage.
- Using unsuitable fuel or fuel that has been stored too long.
- Damages that can be traced to implementation conditions from the rental business.

Cleaning, care, and adjustment work are not recognized as guarantee performances. All guarantee work must be carried out by a SOLO dealer.

For Australia only: Supplementary warranty notes specifically for Australia

To make a claim, contact Clayton Engineering, 26 French Ave, Brendale, Q, 4500 on phone 1300 798 022 or email sales@claytonengineering.com.au. You will be asked to provide proof of purchase and then will be instructed on the procedure for repairing or replacement of the product under warranty. All costs incurred for repair or replace, and additional claims can be discussed at this stage.

This warranty is provided in addition to other rights and remedies you have under law: Our goods come with guarantees that cannot be excluded under the Australian Consumer Law. You are entitled to a replacement or refund for a major failure and for compensation for any other reasonably foreseeable loss or damage. You are also entitled to have the goods repaired or replaced if the goods fail to be of acceptable quality and the failure does not amount to a major failure.



solo[®]

Made in Germany



SOLO
Postfach 60 01 52
D 71050 Sindelfingen

Tel. 07031-301-0
Fax 07031-301-130
info@solo-germany.com

SOLO
P.O.Box 60 01 52
D 71050 Sindelfingen
Germany
Phone+49-7031-301-0
Fax +49-7031-301-149
export@solo-germany.com